



ISO 9001 : 2000

THERMOSTOP INC., 3775 Losch, Longueuil, Quebec, Canada, J3Y 5T7, Tel. : (450) 678-8666, Fax. : (450) 678-7765

INSTALLATION INSTRUCTIONS SECTIONAL OVERHEAD DOORS

Overview of an installation

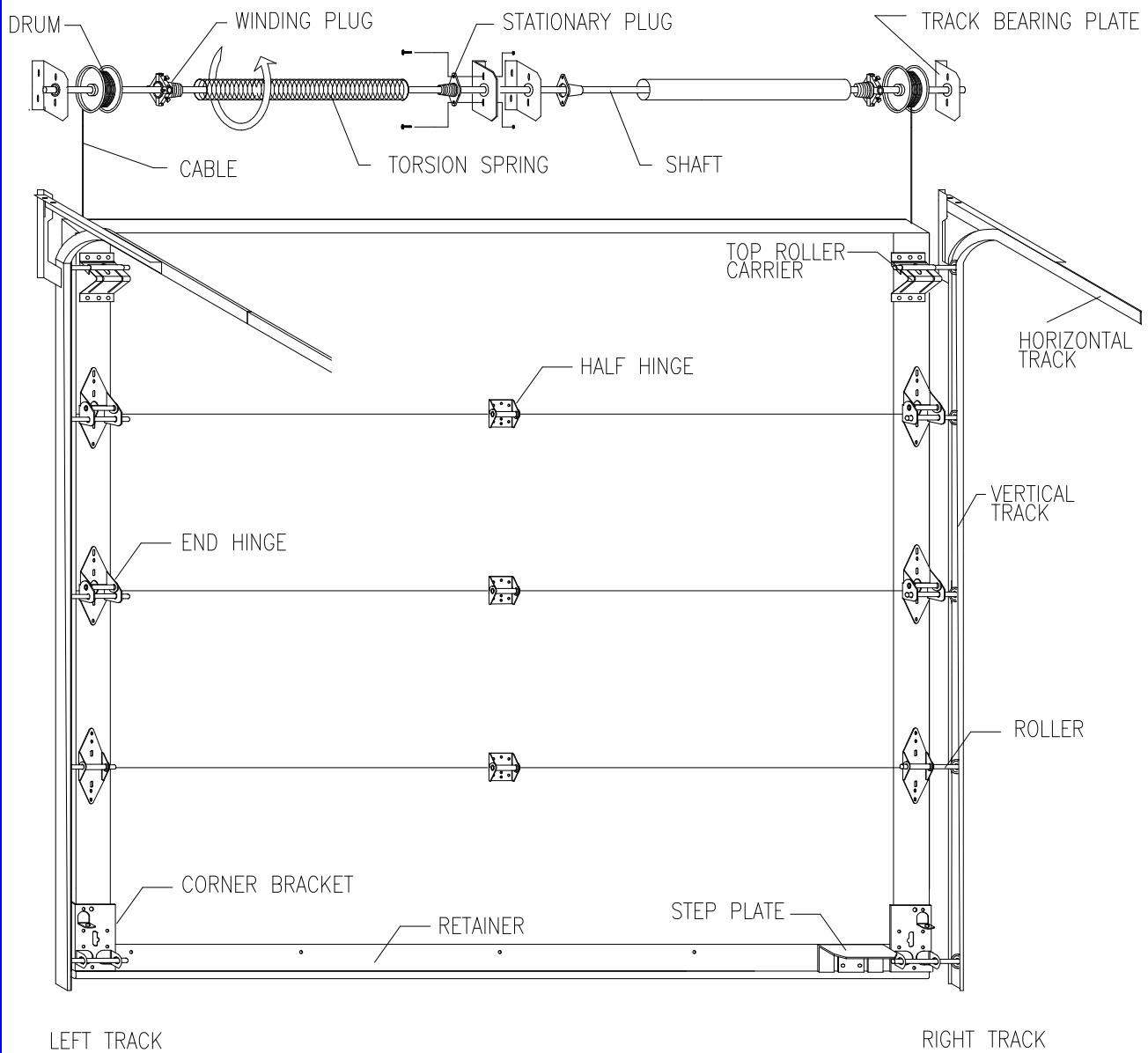



ISO 9001 : 2000

INSTALLATION INSTRUCTIONS SECTIONAL OVERHEAD DOORS

1) VERIFICATION

- 1.1 Verify the dimensions of the opening with those of the door.
- 1.2 Verify door frame for squareness, level etc. Ensure that location of frame extensions are as per indications given in the shop drawings.
- 1.3 Verify the material received with the packing slip.

2) PREPARATION

2.1. BOTTOM CORNER BRACKET

If the corner brackets supplied are models FSB-23, BB-5L, BB7 & BB9, it is not necessary to notch the bottom section. For corner bracket model, the notches are done at the factory (figure 1). All corner brackets must be installed with 1/4" x 3/4" self-drilling screws.

2.2. HINGES AND OTHER HARDWARE ACCESSORIES

- Lay the bottom section (inside sheeting facing up) on two (2) wood-horses.
- Slide the U rubber seal into the aluminum retainer at the bottom of the section (figure 2).

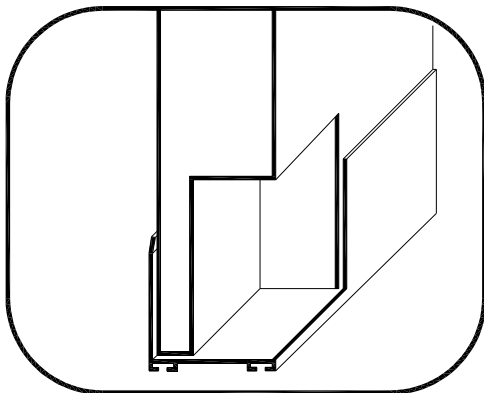

Figure 1

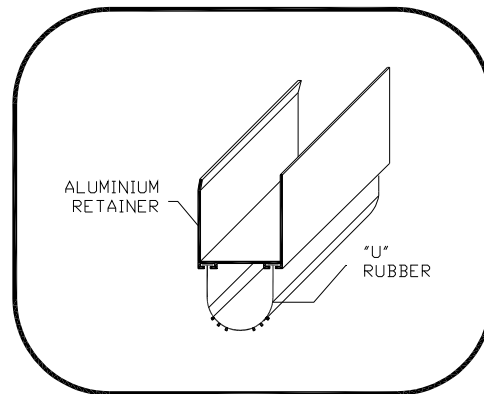

Figure 2



ISO 9001 : 2000

THERMOSTOP INC., 3775 Losch, Longueuil, Quebec, Canada, J3Y 5T7, Tel. : (450) 678-8666, Fax. : (450) 678-7765

- Attach the lower part of the end hinges to the upper end of each section with the 1/4" x 3/4" self-drilling screws : end hinges # 1 on bottom section, end hinges # 2 on second section, and so on, except for the top section where top roller carriers will be used.
- Attach the lower part of the intermediate hinges (half-hinges) to the top part of each section with 1/4" x 1" metal screws at equal intervals (maximum of 4 feet wide).

NOTE: Please do not tighten the screws too hard to avoid stripping the metal.

2.3. REINFORCING STEEL STRUT

NOTE: Steel struts can be installed at the top or at the bottom part of the section.

- Install the strut plates on the bottom (or top) part of the intermediate hinges using the 1/4" x 1" metal screws.
- Hold in place the steel struts with the strut clips and attach the clips to the strut plates (fig. 3) with 1/4" x 1" metal screws.

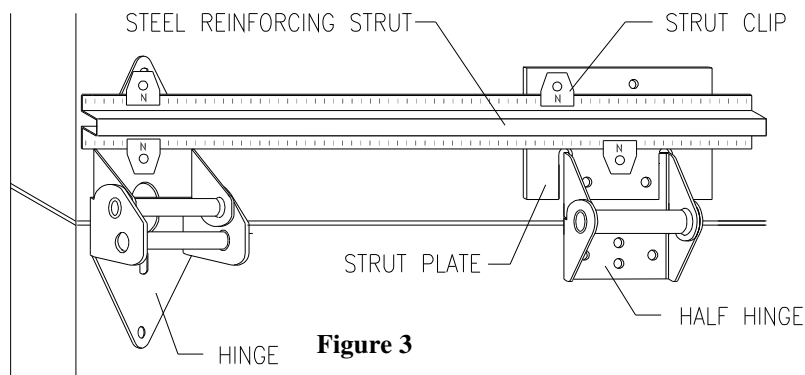

Figure 3

3) INSTALLATION OF TRACKS

Ensure that the horizontal and the vertical tracks correspond to the appropriate door.

NOTE: Vertical tracks are straight whereas horizontal tracks have a curve.

3.1. VERTICAL TRACKS

3.1.1 Tracks installed on wood jambs

- Make 3/16" guide holes. Fasten right vertical track to door frame with 5/16" x 2" lag screws .
- Insert the bottom section into the opening and level with shims (figure 4).
- Insert rollers in the end hinge (right) and in the bottom corner

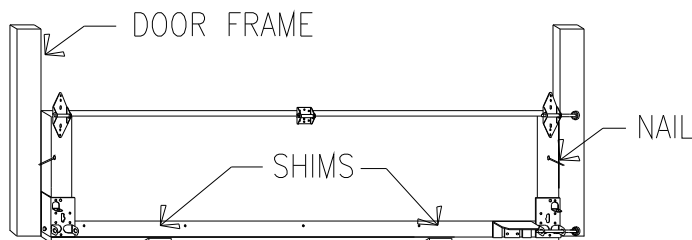

Figure 4

bracket (right) and slide them into the track (right) by leaving a 1/2" gap between door and track (figure 5).

- Insert roller in the end hinge (right) of the second section and slide it into the track (figure 6).
- Repeat with the other sections by aligning the sections one on top of the other.
- Insert rollers into left corner bracket and into the left end hinges slide them into the vertical left track.
- Fasten the left track to door frame by leaving a 1/2" gap between door and track.

NOTE: Please note that for steel jamb (frame), the support angle is reverse.

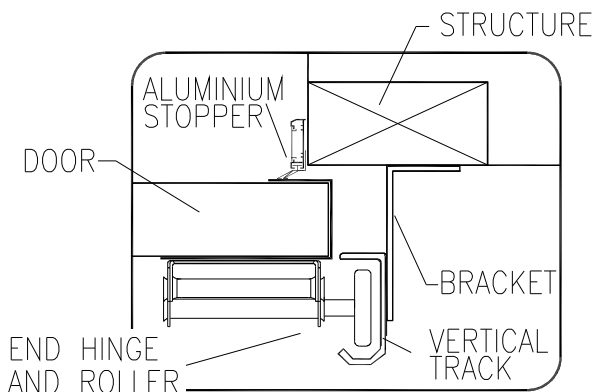

Figure 5

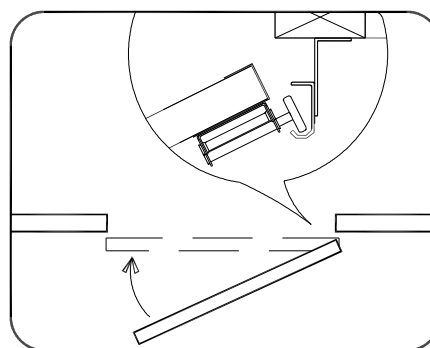

Figure 6

3.1.2 Tracks installed on steel frame:

NOTE: Tracks can be welded to steel frame instead of being fastened with screws.

- Make 9/32" guide holes. Fasten right track to door frame using 1/4"x 3/4" self-tapped screws (see list, ref. # 4).
- Thereafter, follow the same procedure as with wood frame.
- Next fasten the top of the hinges to the bottom of the next section.
- Install and adjust the top roller carriers in such a way that the door will be parallel to the frame, on the whole door width (figure 7).

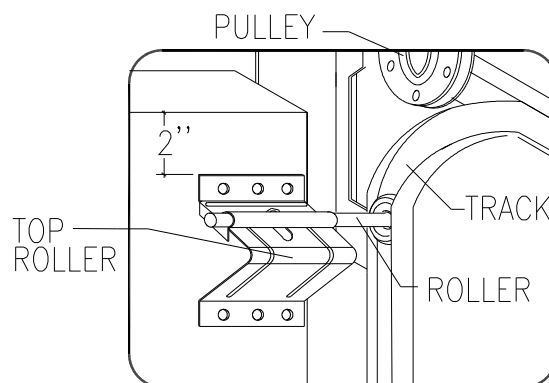
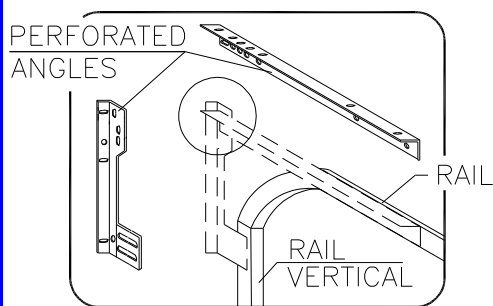
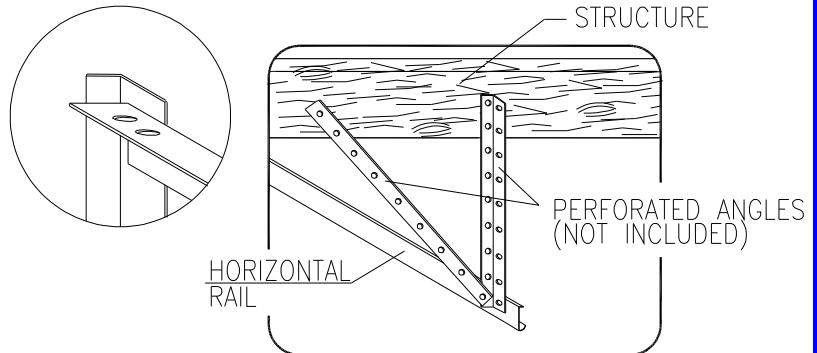

Figure 7

3.2. HORIZONTAL TRACKS:

3.2.1 Standard lift and high-lift

- Fasten the horizontal track to the support bracket of the vertical track using two (2) bolts with locks washers and nuts (figure 8)
- Join the vertical track with the curve of the horizontal track using two (2) rib neck bolts 5/16" x 3/4".
When some high-lift tracks come in three parts (instead of two), the same type of rib neck bolts are used to attach the different parts of tracks together. (Figure 8)
- Fasten the bearing plates (pre-installed on tracks) to the building structure using lag bolts for wood frame or self-tapped screws for steel frame.
- Fasten the horizontal tracks to the building structure, at the back, using perforated steel angles (not supplied) (figure 9) by ensuring that these tracks are parallel and leveled.

**Figure 8****Figure 9**

NOTE: For standard lift, ensure a slope of 1/8" by linear foot.

2.3.2 Full vertical lift

- There is no need to fasten the vertical and horizontal tracks together as they come pre-welded in one piece. For the other steps, follow the same procedure as described before.

NOTE: At this stage , you can tighten all the hinges and the corner brackets.

4) MOUNTING OF TORSION SPRINGS

Keep the door in closed position.

4.1. 1 SPRING OR 2 SPRINGS (1 shaft, 1 or 2 intermediate bracket(s)) (Figure 10)

- Lay the spring assembly on the floor, in front of the opening, with the winding plug to the left. If the assembly consists of two (2) springs, the second spring (right) is mounted with the winding plug on the right. The two stationary plugs are attached to the same intermediate bracket.

NOTE: The direction of the wire is always towards the wall.

- Slide the right drum to the right side and the left drum to the left side of the shaft.
- Lift the assembly and slide the bar into the track brackets.
- Support the middle of the shaft in such a way that it is leveled and attach the intermediate bracket to the building structure using lag screws if it is wood frame or using self-tapping screws if it is steel frame.

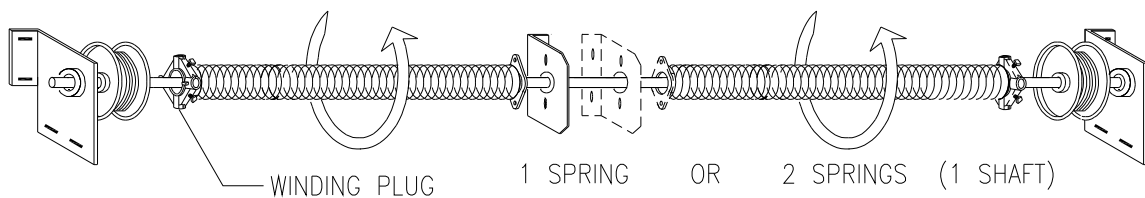

Figure 10

4.2. 2 SPRINGS (2 shafts, 2 intermediate brackets) 4 SPRINGS (2 shafts, 4 intermediate brackets) (Figure 11, next page)

- Lay the assembly on the floor in front of the opening, the mounting plugs for the springs for each shaft, situated on each side of the door.
- Each stationary plug is attached to an intermediate bracket.
- Connect the 2 shafts with a coupling.
- Same procedure as in the preceding case.



ISO 9001 : 2000

THERMOSTOP INC., 3775 Losch, Longueuil, Quebec, Canada, J3Y 5T7, Tel. : (450) 678-8666, Fax. : (450) 678-7765

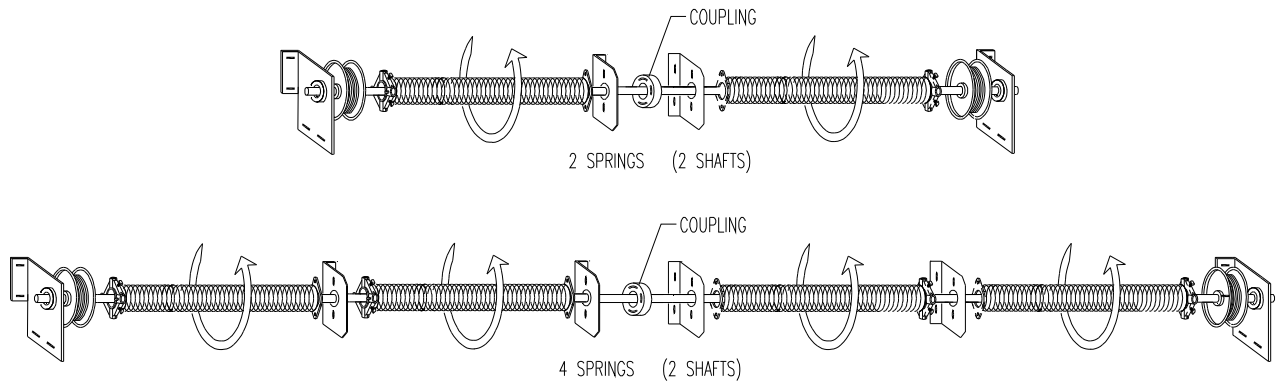

Figure 11

4.3. SPRINGS FOR LOW HEADROOM:

The difference is the drums will be installed outside of the tracks (figure 12). Special bottom corner brackets (BB-5L) will allow the attachment of the cables, outside the tracks.

2 ways to install springs for low headroom:

- 4.3.1. Install the springs above the door opening as described before.
- 4.3.2. Install the springs as described before, but at the back of the horizontal tracks, facing the opening. Slide the cable around the pulley located at the exterior side of each horizontal track and then into the drum (figure 13)

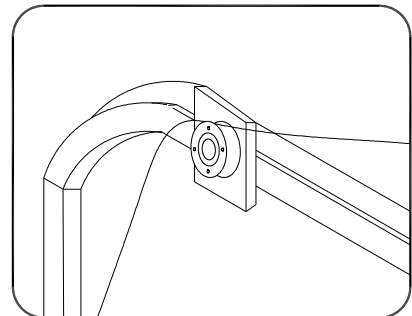
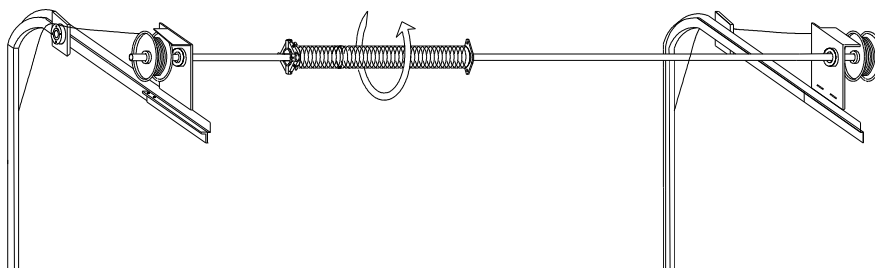
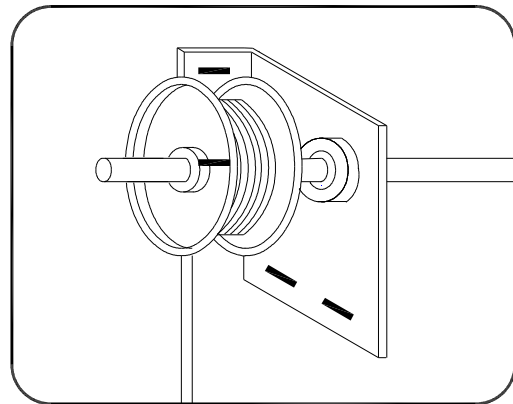

Figure 12

5) SPRINGS ADJUSTMENT

NOTE: Please note that the right drum has its cable slot located at the far right side of the drum. For the left drum, the cable slot is at the far left side of the drum.

- Attach the pre-assembled end of the cables to the corner bracket and insert the other end of the cables into the drums.
- Ensure to start the cables at the same position on both drums and that both cables have the same length.
- Turn the drums (to have the cables wrapping around the drums) until the cables are tense.

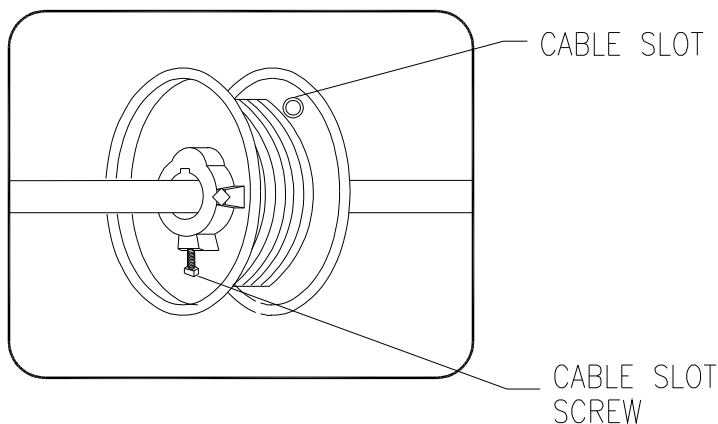

Figure 13

- Insert keys into key ways if it is a solid shaft.
- Position the drums at 1/2" of the tracks and tighten the screws. (figure 13)
- Ensure that the tension is the same for the two cables.
- Block the bar using a pair of vice-grips

IMPORTANT: Extreme caution should be taken for the following tasks. Serious injuries can occur if the following procedure is not follow properly or if inappropriate tools are used.

- Ensure that shaft is blocked.
- Untighten screws of adjustable plugs.
- Using steel bars of 1/2" diameter, 18" long (not supplied), wind the cones upward for the recommended number of turns indicated on the bearing plate.(figure 14)
- Tighten properly the adjustable plugs.
- Remove steel bars and vice-grips.
- If door is too heavy, increase number of turns. If it is too light, decrease number of turns.



ISO 9001 : 2000

THERMOSTOP INC., 3775 Losch, Longueuil, Quebec, Canada, J3Y 5T7, Tel. : (450) 678-8666, Fax. : (450) 678-7765

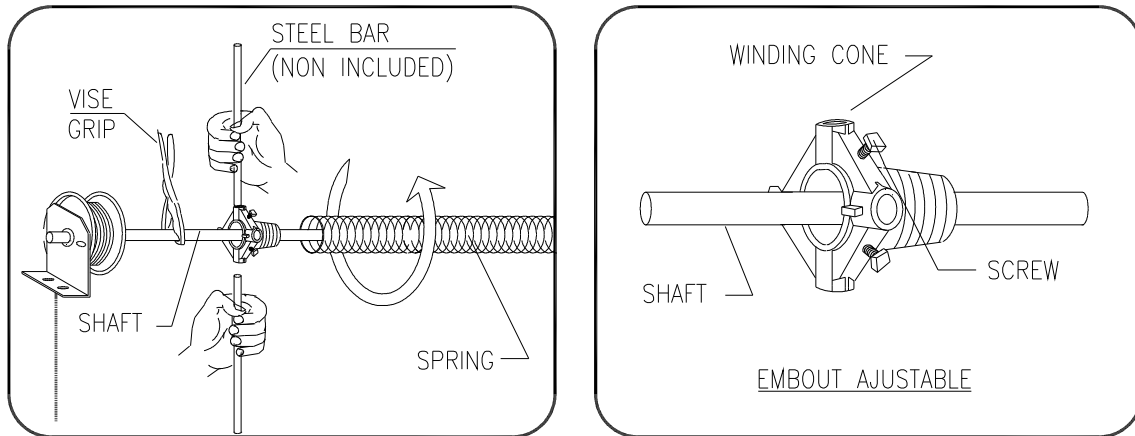

Figure 14